

PUMPMASTER 45 -10:1 RATIO OIL PUMPS

PM45 HEAVY-DUTY SERIES

HEAVY-DUTY PRESSURE FLOW PUMPS

Double acting air operated moderate pressure pump for very large oil systems or when low air pressure or cold temperatures would limit pump performance. Built in port for optional (PN 609 008) pressure relief valve. **Flange mounted pumps.** Pump 536 011 can also use bung adaptor (PN: 360 006) for bung mounting.



PRODUCTS HANDLED

- Synthetic and mineral based oil.
- Hydraulic oil.
- Gear lube.
- Transmission fluid.

MARKETS

- Large auto and truck dealers.
- Construction equipment maintenance.
- Mining equipment maintenance.
- Railroad and mass transit maintenance.
- Large fleets.
- Lube trucks.
- Marine.
- In plant oil distribution.

MODELS		
PART No.	APPLICATION	WEIGHT
536 031	Universal stub pump. Flange mounted pump, bung bushing optional	36 lb (16,5 kg)
536 011	55 gal (205 l) drum. Flange mounted pump, bung bushing optional	38 lb (17 kg)

TECHNICAL DATA PRESSURE RATIO 10:1	
Air pressure operating range	20 to 170 psi (1,5 to 12 bar)
Air consumption (1)	30 scfm (850 NI/min)
Maximum fluid outlet pressure	1,700 psi (120 bar)
Air motor effective diameter	4 1/2" (115 mm)
Air motor stroke	4" (100 mm)
Delivery at 80 cpm	4 gal/min (15 l/min)
Maximum free flow delivery	17.2 gal/min (65 l/min)
Air inlet	1/2 " NPTF
Fluid inlet	1 1/2 " NPTF
Fluid outlet	3/4" NPTF
Wetted and seal materials	Cast iron / Hard chromed steel / Steel / Polyurethane / NBR
Noise level (2)	80 dB
Manual	853 812

DIMENSIONS Inches - (mm)		
PART No.	536 031	536 011
A	28" (702)	54" (1.357)
B	20" (502)	20" (502)
C	2" (54)	2" (54)
D	8" (200)	34" (855)

(1) Maximum air consumption with 72 psi (5 bar) air inlet pressure and 80 cpm.
 (2) Maximum noise level measured at 3' (1 m) from the pump, 100 psi (7 bar) air pressure and free delivery.

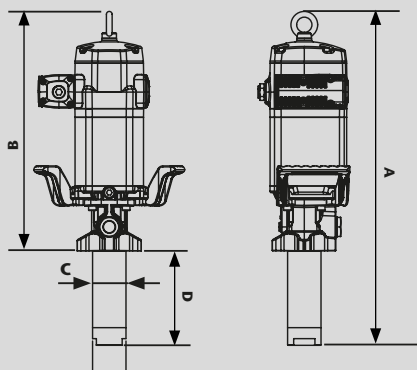
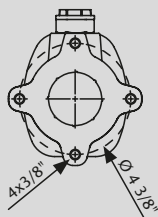

SAE 10, 70 °F (21 °C) CAPACITY CURVE

